

T. L. KNAPP.
TYPE WRITING MACHINE.
APPLICATION FILED DEC. 13, 1907.

969,483.

Patented Sept. 6, 1910

4 SHEETS—SHEET 1.

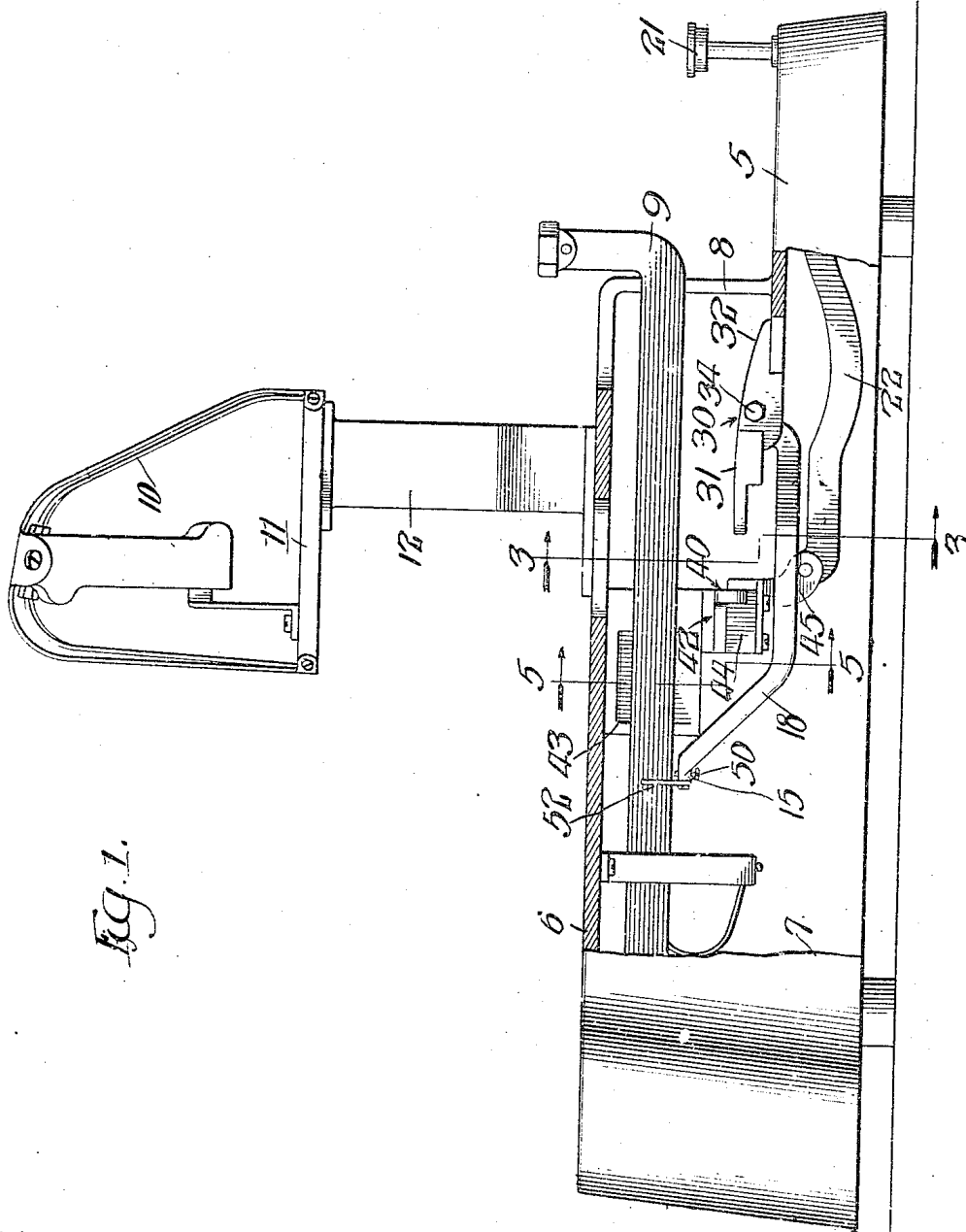

Fig. 1.

Witnesses:
J. H. Alfords
L. R. Wilkins

Inventor:
Theon L. Knapp
by Poole & Brown
Attys.

L. KNAPP.
 TYPE WRITING MACHINE.
 APPLICATION FILED DEC. 13, 1907.

969,483.

Patented Sept. 6, 1910.

4 SHEETS—SHEET 2.

FIG. 7.

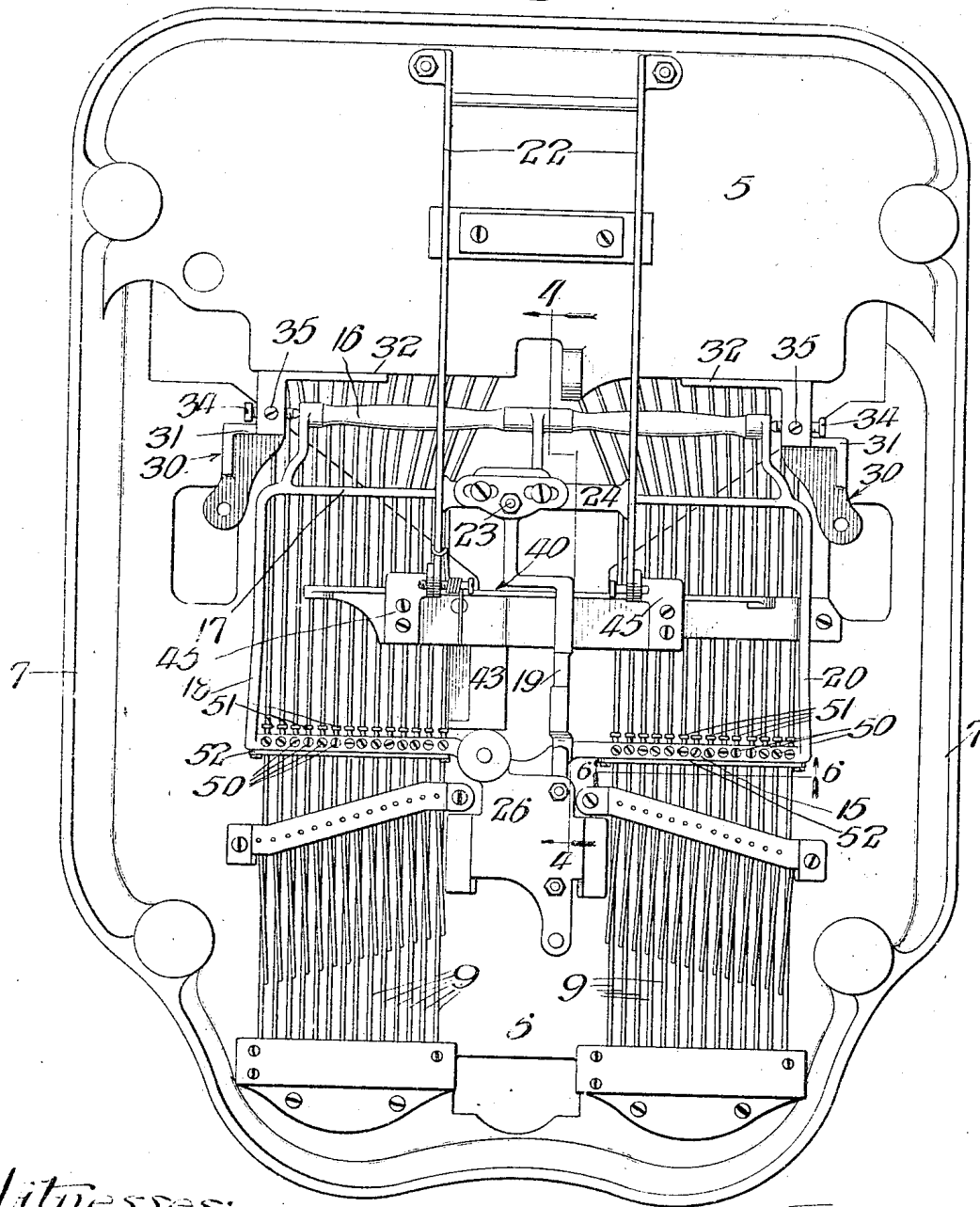

Witnesses:
 P. H. Alfede
 L. Q. Wilkins

Inventor
 Theron L. Knapp
 by Poole & Brown
 Attys

T. L. KNAPP.
 TYPE WRITING MACHINE.
 APPLICATION FILED DEC. 13, 1907.

969,483.

Patented Sept. 6, 1910.

4 SHEETS—SHEET 3.

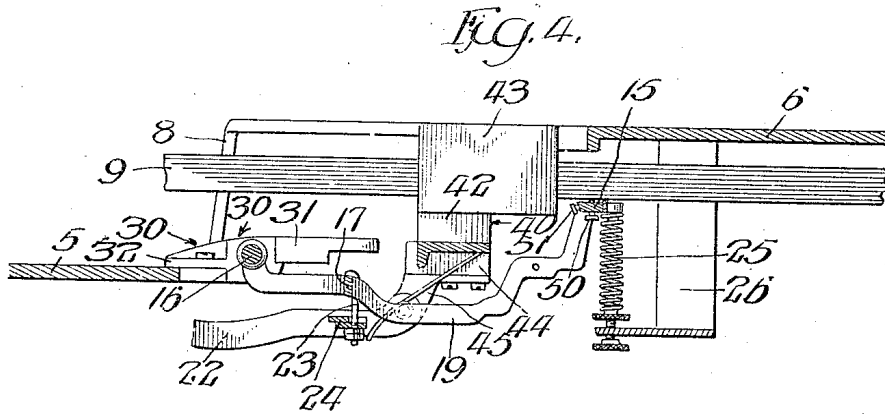
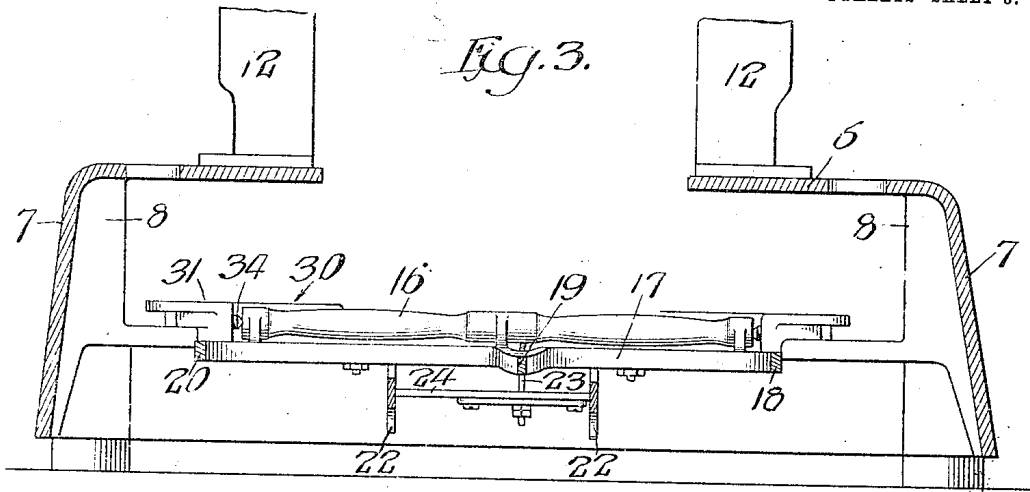

Witnesses:
 P. H. Alfredo
 G. R. Wilkins

Inventor:
 Theron L. Knapp
 by Poole + Brown
 Attys

969,483.

Patented Sept. 6, 1910.

4 SHEETS—SHEET 4.

Fig. 5

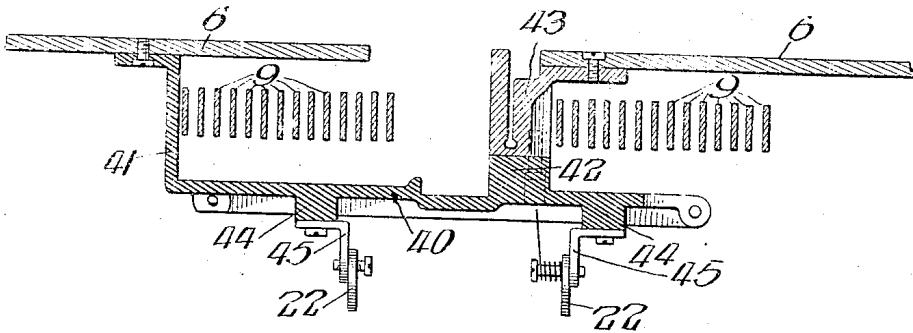

Fig. 6.

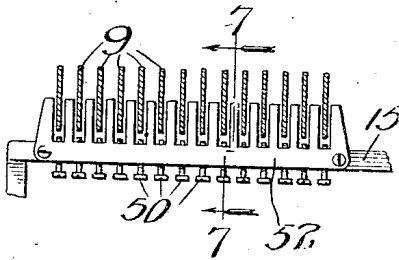

Fig. 7.

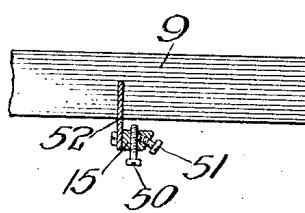

Fig. 8.

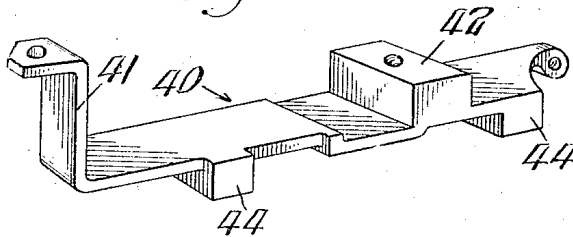
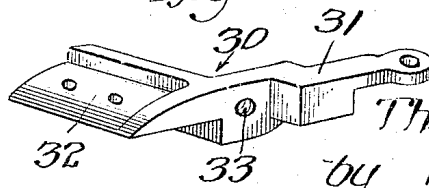

Fig. 9.



Witnesses:
 J. N. Alfreds
 J. R. Wilkins

Inventor
 Theron L. Knapp
 by Poole & Brown
 Attys

UNITED STATES PATENT OFFICE.

HERON L. KNAPP, OF WOODSTOCK, ILLINOIS, ASSIGNOR TO THE OLIVER TYPEWRITER COMPANY, OF CHICAGO, ILLINOIS, A CORPORATION OF ILLINOIS.

TYPE-WRITING MACHINE.

969,483.

Specification of Letters Patent.

Patented Sept. 6, 1910.

Application filed December 13, 1907. Serial No. 406,338.

To all whom it may concern:

Be it known that I, THERON L. KNAPP, a citizen of the United States, and a resident of Woodstock, in the county of McHenry and State of Illinois, have invented certain new and useful Improvements in Type-Writing Machines; and I do hereby declare that the following is a full, clear, and exact description thereof, reference being had to the accompanying drawings, and to the letters of reference marked thereon, which form a part of this specification.

This invention relates to improvements in typewriting machines and it embraces improvements in several features of said machines intended more particularly for application to machines of the kind known as the "Oliver" typewriter, such as is shown and described, in the prior patent granted to Thomas Oliver, Number 599,863, March 1st, 1898. Some of the improvements herein described and claimed are, however, applicable to machines which differ in construction from said "Oliver" machines.

The invention consists in the matters hereinafter described and pointed out in the appended claims.

My invention may be more readily understood by reference to the accompanying drawings, in which,—

Figure 1 is a view partially in side elevation and partially in section of a typewriting machine embodying my invention. Fig. 2 is a view of the machine from beneath. Fig. 3 is a detail, vertical transverse section, taken on line 3—3 of Fig. 1. Fig. 4 is a detail, vertical section, taken on line 4—4 of Fig. 2. Fig. 5 is a detail, vertical section, taken on line 5—5 of Fig. 1. Fig. 6 is a vertical section on line 6—6 of Fig. 2. Fig. 7 is a vertical section on line 7—7 of Fig. 6. Fig. 8 is a view in perspective of the transverse, horizontal frame bar forming a part of the invention. Fig. 9 is a view in perspective of one of the frame brackets forming a part of the invention.

First referring, briefly, to the general features of construction in the machine illustrated in the accompanying drawings, these correspond with the machine shown in said prior Patent No. 599,863, and in Patent No. 834,565, granted to Cross and Griffiths, October 30th, 1906. As shown in said drawings, the base-plate of the machine is provided with a horizontal, lower, forward portion 5.

and with a rear, elevated, horizontal portion 6. The forward lower part and the rear elevated parts 5 and 6, are made integral with a depending marginal base-flange 7 extending entirely around the base-plate. At the forward part of said rear elevated portion, the latter is connected at the sides of the base-plate with the forward lower part 5 by nearly upright walls 8, 8 between which is an opening through which the key-levers extend.

9, 9 designate the key-levers which extend from front to rear of the base-plate; said levers being located with their forward ends above the forward, horizontal part 5 and their rear portions beneath the rear elevated part 6 of the said base-plate, and arranged in two laterally separated groups, located on opposite sides of the longitudinal center line of the machine. Said levers have operative connection with type-bars, of the form employed in said "Oliver" typewriting machine, which type-bars are mounted in two groups, located at opposite sides of the center line of the machine. One of said type bars is indicated by 10, the same being shown as mounted in a supporting frame 11 which is attached to the upper end of one of the two frame standards 12, 12, which are attached to the elevated, rear part 6 of the base-plate.

15 indicates the universal bar of the machine through the medium of which the letter spacing devices of the machine are operated and which extends transversely beneath and is adapted for actuation by all of the key-levers. Said universal bar constitutes a part of an oscillating frame which is formed by means of the said universal bar, a transverse rock-shaft 16 arranged parallel with the universal bar at the front part of the machine, a transverse bar 17 arranged adjacent to and at the rear of said rock-shaft 16, and three arms 18, 19, 20 which extend from front to rear of the machine and rigidly connect said rock-shaft 16 with the bar 17 and with the universal bar.

21 indicates the space-key and 22, 22 the space-key levers. The said space-key levers extend rearwardly from the space-key beneath the key-levers and the universal-bar frame, and are pivotally supported at their rear ends as hereinafter described. The space-key levers are connected with the universal-bar frame by means of an upright

connecting rod 23 attached to a cross-piece 24 on the said levers and engaged with the cross-bar 17 of the said frame. The universal-bar 15 is held yieldingly in its elevated position by means of an expansively acting spiral spring 25 which is arranged vertically beneath said universal-bar and bears against the same at its upper end. The lower end of said spring is supported upon a bracket 26 which is secured to and depends from the base-plate.

Now referring to the features illustrated which relate more particularly to the present invention, one feature of my invention relates to the means for supporting or sustaining upon the base-plate operative parts of the machine at points adjacent to the front of the base-plate and beneath the forward ends of the key-levers, the supporting means illustrated in the accompanying drawings being employed to sustain the forward end of the universal bar frame. The means illustrated for these purposes, consists of a pair of bracket-members 30, 30 which are arranged at opposite sides of the base-plate and are attached to and extend rearwardly from the rear margin of the lower, horizontal, forward part 5 of the said base-plate. Said bracket members are employed, in the construction illustrated, to afford pivotal support for the rock-shaft 16 of the universal bar frame, which is arranged horizontally below the level of the key-levers near the front of the machine. Each of said bracket-members (Fig. 9) consists of a bracket portion 31 which extends rearwardly from the part 5 of the base-plate and a horizontal base portion 32 arranged at right angles to the bracket portion 31. Said horizontal base portion 32 extends transversely of the machine and rests on the top surface of the said lower, forward part 5 of the base-plate, to which it is secured by screws or bolts. Each of the bracket members is provided at its bracket portion 31 with a screw-threaded, horizontal aperture 33 in which is inserted a screw-threaded pivot-stud 34 (Fig. 2). Said pivot-studs 34, 34 are made conical at their inner ends and are adapted to engage conical recesses in the ends of the rock-shaft 16, and to thereby form the stationary parts of pivot bearings for the ends of the said rock-shaft. Set-screws 35, 35, inserted into the bracket members at right angles to the pivot-studs, act on the latter to hold the same from movement when adjusted.

Another novel feature of my invention relates to the means for supporting from the base-plate of the machine an operative part or parts located below the key-levers, forward of the universal bar.

40 (Figs. 2, 5 and 8) indicates a horizontal frame-bar which is arranged transversely beneath the key-levers, and is sup-

ported rigidly from the rear elevated part 6 of the base-plate. Said frame-bar has at its right-hand end an upright portion 41 which rises to the horizontal rear part 6 of the base-plate, and is bent at its upper end to form a horizontal portion which is attached to the said part 6 by a screw or bolt. At a point between its ends the said frame-bar 40 is provided with an integral, upwardly extending lug 42 adapted to bear at its upper end against and secured to a block 43, which is attached to and depends from the elevated part 6 of the base-plate, in the space between the two groups of key-levers. Said frame-bar is adapted to afford support for the rear ends of the space key-levers 22, 22. For this purpose it is provided, on its under side, with lugs 44, 44 to which are attached by means of screws, depending brackets 45, 45 to which are pivoted the rear ends of the said space-key levers.

In a machine having a base-plate made with a rear elevated part extending above the key-levers, as illustrated, a horizontal transverse frame-bar, attached to the base-plate below the key-levers by connecting members rising from the frame-bar to the elevated part of the base-plate as described, affords a strong and rigid support for the pivots of the space key levers and may be employed to support or sustain any other operative parts of the machine which require support at points beneath the said key-levers.

Another novel feature included in my invention relates to features of construction in the universal-bar 15 in the portion thereof with which the several key-levers make contact when depressed. In said universal-bar are mounted a plurality of vertically arranged adjusting screws 50, 50, one of which is located beneath and in vertical alinement with each of the several key-levers. Said adjusting screws are inserted through the bar from beneath and project at their upper ends above the bar, with their said upper ends in position for contact with the lower edges of the key-levers. Said adjusting screws, being vertically adjustable in the universal-bar, serve as adjustable stops by which the several key-levers may be caused to act with uniform effect upon the universal bar. Associated with each adjusting screw 50 is a set-screw 51 which is inserted through a screw-threaded aperture in the universal-bar at an angle to the adjusting screw. The set-screw 51 is adapted to bear so as to hold the latter from any turning or shifting movement after it has been properly adjusted.

In connection with each of the two groups of key-levers, a vertically slotted guide-plate 52 is rigidly attached to the universal-bar in parallel relation thereto. In the partic-

ular construction illustrated, the guide-plates 52, 52 are secured by screws to the rear face of the universal-bar. Said guide-plates are provided with a plurality of vertical guide-slots adapted to severally engage the key-levers. Said guide-slots are adapted to permit free movement of the universal-bar relatively to the key-levers, and at the same time act to hold said key-levers from a lateral shifting movement relatively to the universal-bar and the adjusting screws 50, 50. Said slotted guide-plates, therefore, serve to always maintain the key-levers in vertical alinement with and in position to engage the several adjusting screws; thereby avoiding liability of either of the key-levers failing to make proper contact with the upper end of the adjusting screw beneath it when the key-lever is depressed.

20 I claim as my invention:—

1. In a typewriting machine, the combination with substantially horizontal key-levers and a base-plate provided with a lower horizontal forward part extending beneath the forward ends of the key-levers, and a higher horizontal rear part extending over the rear portion of the key-levers, of two bracket members, located at opposite sides of the machine, said brackets consisting each of a transversely extending, horizontal base portion which overlaps and is attached to the lower horizontal forward part of the base-plate, and a bracket portion which extends rearwardly from the rear edge of said lower forward part of the base-plate, said brackets affording supports or bearings for operative parts of the machine located at the forward part thereof below the key-levers.

40 2. In a typewriting machine, the combination of a horizontal base-plate, longitudinally extending key-levers arranged below said base-plate in two groups at opposite sides of the center line of the machine, and a transversely arranged, horizontal frame-bar which is located below the key-levers and is provided with upwardly extending parts by which it is rigidly connected with the said base-plate, one of said parts being located between the two groups of key-levers and the other laterally outside of said key-levers.

3. In a typewriting machine, the combination of substantially horizontal key-levers arranged in two groups at opposite sides of the center line of the machine, a base-plate provided with a horizontal lower, forward

portion which extends beneath the forward ends of the key-levers, and a higher, horizontal rear part extending over the rear portions of the key-levers, and a horizontal frame member extending transversely beneath the key-levers and rigidly connected with the elevated rear part of the base-plate by upright connecting members located one between the groups of key-levers and the other laterally exterior to said key-levers, said transverse frame member affording support for operative parts located below the said key-levers.

4. In a typewriting machine, the combination of substantially horizontal key-levers arranged in two groups at opposite sides of the center line of the machine, a base-plate provided with a lower, forward, horizontal portion which extends beneath the forward end of the key-levers, and a higher, rear horizontal portion which extends over the rear portions of the key-levers, a block attached to and depending from the rear, horizontal portion of the base-plate, between the groups of key-levers, and a horizontal, transversely arranged frame bar located below the key-levers, rigidly secured between its ends to said depending block and having at one of its ends an upwardly extending rigid part which is attached to said rear, horizontal part of the base-plate, said frame bar affording support or bearings for operative parts of the machine which are located below the level of the key-levers.

5. In a typewriting machine, the combination of a horizontal base-plate, longitudinally extending, horizontally arranged key-levers located below the base-plate, spacing mechanism which includes a space-key and longitudinally arranged space-key levers, a horizontal frame bar which extends transversely beneath the key-levers and is rigidly attached to the base-plate by upright connecting members located one between the groups of key-levers and the other laterally outside of said key-levers, and bearings for said space-key levers attached to said transverse frame-bar.

In testimony, that I claim the foregoing as my invention I affix my signature in the presence of two witnesses, this 9th day of December A. D. 1907.

THERON L. KNAPP.

Witnesses:

L. L. SCHROEDER,
E. R. HOY.