

C. C. POOLE.
 LINE SPACE INDICATOR FOR TYPE WRITERS.
 APPLICATION FILED MAR. 7, 1906.

929,242.

Patented July 27, 1909.

Fig. 1.

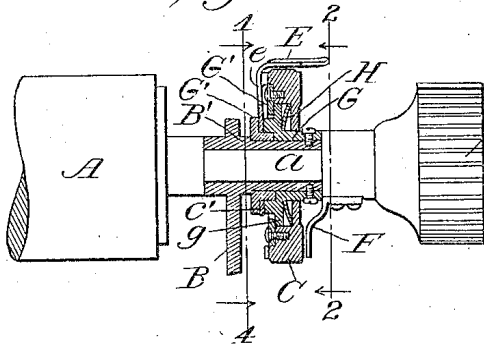

Fig. 2.

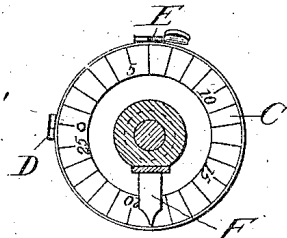

Fig. 3.

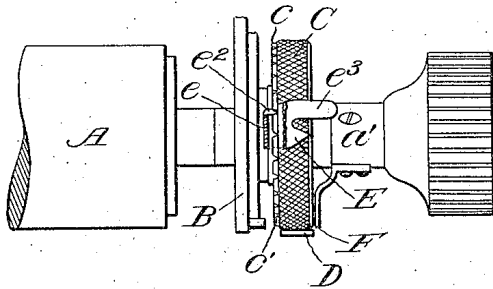

Fig. 4.

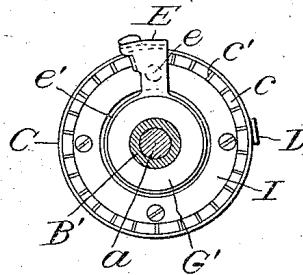

Fig. 6.

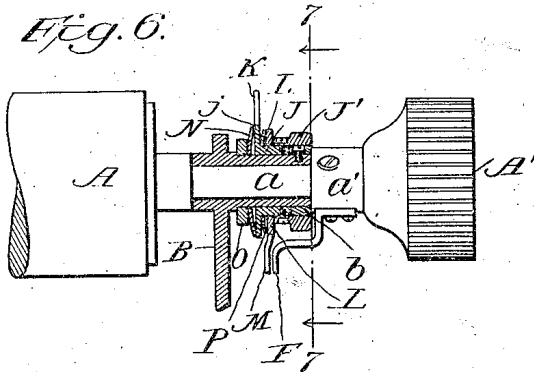
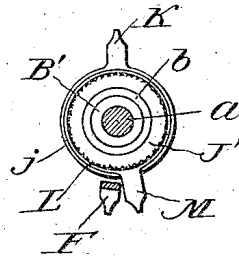

Fig. 7.



Witnesses.
 C. A. Walker
 G. R. Wilkins

Inventor
 Charles C. Poole
 by Poole & Brown
 Attorneys.

UNITED STATES PATENT OFFICE.

CHARLES C. POOLE, OF EVANSTON, ILLINOIS, ASSIGNOR TO THE OLIVER TYPEWRITER COMPANY, OF CHICAGO, ILLINOIS, A CORPORATION OF ILLINOIS.

LINE-SPACE INDICATOR FOR TYPE-WRITERS.

No. 929,242.

Specification of Letters Patent.

Patented July 27, 1909.

Application filed March 7, 1906. Serial No. 304,748.

To all whom it may concern:

Be it known that I, CHARLES C. POOLE, a citizen of the United States, of Evanston, in the county of Cook and State of Illinois, have invented certain new and useful Improvements in Line-Space Indicators for Type-Writers; and I do hereby declare that the following is a full, clear, and exact description thereof, reference being had to the accompanying drawings, and to the letters of reference marked thereon, which form a part of this specification.

This invention relates to novel features of construction in the paper feeding devices of typewriting machines and more especially to indicating means adapted to indicate to the operator the extent to which the platen should be turned backward by hand for inserting new sheets when making carbon copies of a number of writings on a single record strip or sheet with uniform or predetermined spaces between such carbon copies.

The invention consists in the matters hereinafter described and more particularly pointed out in the appended claims.

In the accompanying drawings illustrating my invention: Figure 1 is a sectional view, taken on a vertical plane passing through the central axis of the platen shaft, showing the right hand end of the platen and platen shaft and the turning-knob thereon in side elevation and illustrating the bearing of the platen shaft and parts constituting my invention in section. Fig. 2 is a sectional elevation, taken on line 2—2 of Fig. 1. Fig. 3 is a plan view of the parts shown in Fig. 1. Fig. 4 is a sectional elevation, taken on line 4—4 of Fig. 1. Fig. 5 is a perspective view of the adjustable pointer forming part of the device. Fig. 6 is a sectional view like Fig. 1 illustrating a modified construction of the parts. Fig. 7 is a sectional elevation, taken on line 7—7 of Fig. 6.

As shown in said drawings, A indicates the platen or paper roller, and B the right hand end plate or frame piece of the paper carriage, or frame in which the platen is mounted. The platen-shaft, to which the platen A is secured, is indicated by *a* and said shaft is mounted to turn in a bearing sleeve or hub B¹ which is rigidly attached to the frame plate B. To the outer end of said platen shaft *a* is secured the platen turning knob or wheel A¹ by which the platen may be turned

above described, as illustrated, correspond with those used at present in the type of machine known as the "Oliver".

Referring now more particularly to the form of the device illustrated in Figs. 1 to 5, both inclusive, C indicates an annular member or disk carrying an index finger or pointer D and which is mounted on the frame of the machine or carriage concentrically with the platen shaft and is adapted to be turned or rotated by hand. Said disk C is shown in the drawing as mounted on the end of the bearing sleeve B¹ which is extended outwardly from the frame plate B to receive it. Said disk C is, for convenience, provided with circumferentially spaced graduations or scale marks spaced at uniform angular distances apart to correspond with the line space movements of the platen. The index finger or pointer D is secured to the disk at the zero mark of the scale. Said disk C is, moreover, engaged with the part of the frame on which it is mounted by means adapted to hold the disk from freely turning relatively to the frame, but permitting rotative adjustment of said disk on the said frame. E indicates an index finger or pointer mounted to move concentrically with the disk C which is adjustable circumferentially on or relatively to said disk and is adapted to turn with the disk; said finger or pointer E being adjustable so that it may be placed in varying angular positions with respect to the pointer D or zero point of the disk and being connected with the disk so that it will remain at any point to which it may be moved or adjusted and will then turn with the disk when the latter is rotated by the hand of the operator. F indicates an index finger or pointer which is attached to and turns with the platen shaft or platen and is adapted to co-act with the pointer D or zero mark of the disk and the adjustable pointer E of said disk.

So far as the general ends to be attained are concerned the disk C may be engaged with its bearing on the frame, in the instance illustrated, the stationary sleeve B¹, by any device adapted to hold the disk from freely turning while permitting its rotative adjustment, and the index finger or pointer E may be connected with the disk C by any means adapted to retain the same in any position in which it may be placed with respect to the pointer D or zero mark of the disk, while enabling said pointer E to be readily shifted or

adjusted, relatively to said pointer D or zero mark, circumferentially of the disk. In the preferred embodiment of my invention illustrated in the drawing, the disk C is frictionally engaged with the sleeve B¹ while the pointer E is mounted on an arm which turns on the sleeve B¹ and is held in adjusted position on the disk by an interlocking connection with the disk or by a locking device adapted to hold said pointer to the disk so that it will turn with the latter.

Now referring to the details of construction in the features above referred to illustrated in Figs. 1 to 5 of the drawings: G indicates a collar which surrounds the outer part of the sleeve B¹ and is rigidly secured thereto by screws as shown or otherwise. At its inner end said collar G is provided with an annular flange *g*. The disk C fits upon or around the collar G and in its inner face is formed an annular recess adapted to receive the flange *g* on the collar G. Between the bottom of said annular recess and said flange is located a concave, elastic ring or spring-washer H. Attached to the inner face of the disk by screws or otherwise is a ring I which overlaps the flange *g* and serves to prevent outward movement of the disk relatively to the frame and to thereby maintain the spring-washer H in compression between the disk and flange. The said concave washer H thus confined between the disk and the said flange *g* exerts constant pressure on both of said parts by which is afforded frictional resistance to the turning of the disk so that the disk may be readily turned by hand but will remain in any position to which it may be turned. The pointer E is attached to an elastic or spring-arm *e* formed on or secured to a flat ring *e*¹ which fits or is held within a groove formed between the inner end of the stationary collar G and a ring G² which is applied around the sleeve B¹ and is held in place thereon by the stationary collar G. The pointer E is adapted to be turned or rotated on the sleeve B¹ by the turning of the ring in said groove.

For locking the pointer E to the disk C the latter is provided around the margin of its inner face with a flange *c* which is provided with radial notches *c*¹, spaced to correspond with the scale-marks on the face of the disk, and the arm *e* is provided near its outer end with a holding tooth *e*² adapted to engage either one of said notches *c*¹ and which is pressed toward the disk and held in interlocking relation with one of said notches *c*¹ by the resiliency of the spring-arm *e*. The pointer E has the form of a horizontally and outwardly bent extension of the arm *e* which projects over the marginal surface of the disk C with its outer end adjacent to the scale marks on the outer face of the disk. To permit the pointer E to be easily moved or shifted and the arm *e* to be readily pressed

rearward for the disengaging of its tooth *e*² from the notches *c*¹, said pointer is provided with an outwardly extending arm or finger-piece *e*³ located at one side of the pointer and projecting forward or outside of the outer face of the disk C. By applying the finger to the finger-piece *e*³ and pressing backwardly thereon the arm *e* is released from its locking engagement with the disk and the pointer may then be moved or shifted by the action of the finger on the finger-piece in a manner to turn the pointer around, or move it along the periphery, of the disk.

The pointer F is shown as having the form of a small metal arm secured to the hub or sleeve *a*¹ by which the turning knob A¹ is secured to the shaft *a*.

The disk C is preferably roughened or knurled on its peripheral surface so that it may be readily turned by hand.

The operation of the indicating device described will be understood from the following: The general purpose of the line space indicating device is to indicate to the operator the extent to which the platen must be turned backward when inserting a sheet of paper into the machine, in order to bring the first line of printing the desired distance from the top margin of the paper, according to the space occupied by the heading on the sheet. More particularly, the indicating device is designed for use in cases where it is desired to make out a number of bills or invoices and to make carbon copies of the same on a single strip or long sheet of paper. In a case of this kind, it is desirable that the copies should be spaced as closely as possible on the record strip but at uniform distances apart, or with equal spaces between several records or copies, and the indicating device is employed to enable the operator to readily insert a new sheet for each separate original bill or invoice in such manner that the first printed line of the carbon copy on the record sheet shall be located at a desired distance from the last printed line of the preceding carbon copy thereon. As, for instance, supposing the record strip and a sheet of paper for the original bill or invoice has been together inserted into the machine with carbon paper between them, the first bill or invoice may be printed and the carbon copy will be made in the usual manner on the record strip. The printing of the bill or invoice having been completed, the platen will then be turned to carry the original sheet out of the machine, and the platen then turned backwardly to move or shift the record strip backwardly to such a point which, when a new sheet is inserted, the part of the new sheet on which the first line is to be printed, will be located at such distance from the last line of the carbon copy as to leave a desired space on the record strip between the copies.

In using the indicating device described

the operator sets the pointer E at a distance from the pointer D or zero mark on the disk C, equal to the distance which it is necessary to turn the platen backward after printing the last line of one bill or invoice in order to start a new original sheet into the machine in such manner that the first line of the next bill or invoice when started at its proper place on the sheet will, on the carbon copy sheets, come at a distance desired as 2, 3, or 4 line spaces from the last line of the preceding carbon copy. The setting of the pointers may be effected as follows: In the case of an "Oliver" typewriter, one of the original sheets or blanks for a bill or invoice, which usually has a printed heading, is inserted in the machine with its advance margin against the lower guide roller or gripping roller by which the sheet is fed forward, and in position to be gripped and fed forward when the platen is turned in its usual feeding direction. The pointer F will, at this time, extend in any direction from the platen shaft that it may happen to stand, and the disk is then turned to bring its zero mark opposite the said pointer F and there allowed to remain. The platen is then turned to feed the paper forward until brought into position for printing the first line, which is usually the date line. The platen is then turned forward a space of two or three additional lines according to the distance desired between the carbon copies on the record sheet. The operator, leaving the disk C in the same position at which it was first set, releases the pointer E from the disk and turns said pointer until it is opposite or coincides with the pointer F in the new position of the latter. The angular distance between the zero mark or pointer D and the pointer E will then be equal to the distance which it is necessary to turn back the platen for inserting a new sheet, this distance being represented by the length of the heading on the blank bill or invoice plus the distance around the platen from the gripping roller to the striking point of the type, plus the space to be left between the carbon copies on the record sheet. The parts will now be adjusted for use in connection with the same bill or invoice heads or sheets, so long as it may be desired to use the same.

In the use of the device in printing, the bill or invoice sheet and the record sheet are inserted into the machine, with the carbon paper between them, in the usual manner. After the printing of the first invoice is finished, on completion of the last line thereof, the disk C will be turned to bring the pointer E thereon opposite the rotating pointer F and the disk allowed to remain in this position. The platen will then be turned forward far enough to remove the original sheet and then turned backward until the pointer F is carried past the pointer E and around the disk until it reaches the zero mark or

pointer D, when it is stopped. The platen will then be in position for the insertion of the next original sheet which will be inserted by thrusting it into the machine until its top edge comes in contact with the first guide roller by which the sheet is gripped to the platen, and the platen will then be turned forwardly to carry the record sheet and the new original sheet into position for printing the first line on said new original sheet.

It follows that, by the use of the device described, the operator having once determined the angular distance or number of line spaces through which the platen must be turned backwardly before starting a new sheet into the machine, in every instance, or when inserting each new original sheet for an original bill or invoice, is enabled to invariably turn the platen backward the same distance, according to the angular distance between the zero-mark or pointer D and the pointer E on the disk. The operator will thus be able to invariably bring the first printed line of each carbon copy on the record sheet at the same distance from the last printed line of the previously made copy on said record sheet, thereby leaving uniform spaces between the several carbon copies on the record sheet.

The graduations or scale-marks on the disk C are not essential or necessary but are useful only to enable the pointer E to be set by the operator in desired positions for original sheets having headings of different widths, when the operator knows from recollection places on the scale at which the pointer must be located for the different original sheets. Moreover, as the graduations correspond with the line spaces, if the operator desires to make the spaces between carbon copies greater or less this can be done by merely shifting the pointer E backward or forward one or more spaces as desired.

Inasmuch as the angular distance between the pointers D and E will, in any case, correspond with the extent of backward turning movement of the platen required, it is immaterial whether the pointer D or zero-mark, or the adjustable pointer E be used to mark the starting point of the backward turning movement. It is somewhat more convenient, however, in first effecting adjustment of the pointer E that the scale be numbered from the zero mark in the manner indicated or like the numbering on a clock dial so that the numbers shall indicate the extent of forward movement of the platen and in that case in turning the platen backward, in inserting a new original sheet, the operator will start from the pointer E and turn back to the zero-mark or pointer D.

The graduations or scale marks on the disk being used merely for convenience in setting the pointer E from memory and not being necessary for use in setting the ad-

adjustable pointer, the disk C and its graduations may be omitted and in that case the pointer B or the zero mark on the disk may be replaced by an indicating arm or pointer adapted to co-act with a like pointer having angular adjustment with respect to the first pointer, both of said pointers being adapted to be turned, or to have rotative adjustment together, on the machine frame.

A construction of this latter kind is shown in Figs. 6 and 7. In this instance, a rotative collar J surrounds the sleeve B¹ and has attached to its inner end a flange j to which is attached a pointer K. On the collar J is mounted a ring L to which is attached a pointer M. On the outer end of the collar J is secured a ring J¹, knurled at its edge to enable said collar and the pointer K to be readily turned on the sleeve B¹. Frictional connection between the collar J and the sleeve B¹ is afforded by means of a concave spring metal ring or washer N inserted between the flange j on the inner end of said collar and a fixed ring O on the said sleeve B¹. The collar J is held from endwise movement on the hub B¹ by means of a ring b secured to the outer end of the hub within the outer end of the ring J¹. Frictional connection between the ring L and the collar J will be afforded by means of a like spring-washer P interposed between the flange j and the said ring L. The platen shaft will, in this instance, have a pointer F affixed thereto in the same manner as before described. The operation of the form of the device shown in said Figs. 6 and 7 will be the same as that of the form first described; the distance through which the platen must be turned backward to give uniform spaces between the carbon copies on the record sheet being determined by the angular distance apart of the relatively adjustable pointers K and M which are adapted to be turned together by the fingers of the operator applied to the knurled ring J¹. The original setting of the pointers K and M in this form of construction may be conveniently effected as follows: One of the sheets, with a printed heading, on which the bill or invoice is to be printed, is placed in the machine with its upper edge in position to be gripped by the first guide roller. The collar J and pointer K will then be turned to bring said pointer K opposite the revolving pointer F. The platen will then be turned forward to carry the sheet into position for printing the first line thereon and two, three or four additional line spaces as required for the distance between the carbon copies on the record sheet. The pointer M will then be turned on the sleeve J until it reaches a position coinciding with the new position of the pointer F, and the distance between the two pointers M and K will then indicate the angular distance that the platen must be

turned backward in inserting each new or additional sheet, as before described.

I claim as my invention:—

1. The combination with a rotative platen and a frame in which said platen is mounted, said frame being provided with a fixed bearing sleeve concentric with the platen, of two pointers which are mounted to turn on said bearing sleeve and have rotative adjustment on said sleeve and also have angular adjustment relatively to each other and a third pointer which is rigidly connected and turns with the platen shaft.

2. The combination with a rotative platen and its shaft, and a frame in which said shaft is mounted, said frame having a fixed bearing sleeve affording a bearing for the shaft, of two pointers mounted on said bearing sleeve and having rotative adjustment thereon and angular adjustment relatively to each other, and a third pointer attached to and turning with the shaft.

3. The combination with a rotative platen and a frame in which the same is mounted, said frame being provided with a fixed bearing sleeve concentric with the platen, of two pointers mounted and adapted to turn on said sleeve, one of said pointers having frictional engagement with said sleeve and said pointers having angular adjustment relatively to each other, and a third pointer which is rigidly connected and turns with the platen shaft.

4. The combination with a rotative platen and a frame in which it is mounted, said frame being provided with a fixed bearing sleeve concentric with the platen, of two pointers mounted on said sleeve and having rotative adjustment thereon, said pointers having angular adjustment relatively to each other, means affording interlocking connection of said pointers with each other, and a third pointer which is rigidly connected and turns with the platen shaft.

5. The combination with a rotative platen and a frame in which it is mounted, said frame being provided with a fixed bearing sleeve concentric with the platen, of a disk mounted on said bearing sleeve and provided with scale marks or graduations, a pointer mounted on the frame and cooperating with the zero point of the disk to indicate angular distances, and a pointer mounted on the platen shaft.

6. The combination with a rotative platen and a frame in which said platen is mounted, said frame being provided with a fixed bearing sleeve concentric with the platen, of an annular member mounted on the said bearing sleeve, means affording frictional engagement of said annular member with the frame, a second annular member also mounted on the said bearing sleeve, two pointers carried by said annular members, means for locking the pointers on said annular members in a

desired angular relation to each other and a third pointer which is rigidly connected and turns with the platen shaft.

7. The combination with a rotative platen
5 and a frame in which the same is mounted, said frame being provided with a fixed bearing sleeve concentric with the platen, of a disk mounted on the said sleeve and having rotative adjustment thereon, said disk hav-
10 ing a knurled peripheral surface and scale marks or graduations on one of its side faces, friction means for yieldingly holding the disk from turning on the bearing sleeve, a pointer having rotative adjustment on the

said sleeve, and angular adjustment rela- 15 tively to the disk, means for locking said pointer in adjusted position relatively to the disk, and a pointer which is rigidly connected and turns with the platen shaft.

In testimony, that I claim the foregoing 20 as my invention I affix my signature in presence of two witnesses, this 7th day of March A. D. 1906.

CHARLES C. POOLE.

Witnesses:

BLANCHE L. CHADWELL,
G. R. WILKINS.