

H. CROSS.  
TYPE WRITER.

APPLICATION FILED NOV. 7, 1905.

4 SHEETS—SHEET 1.

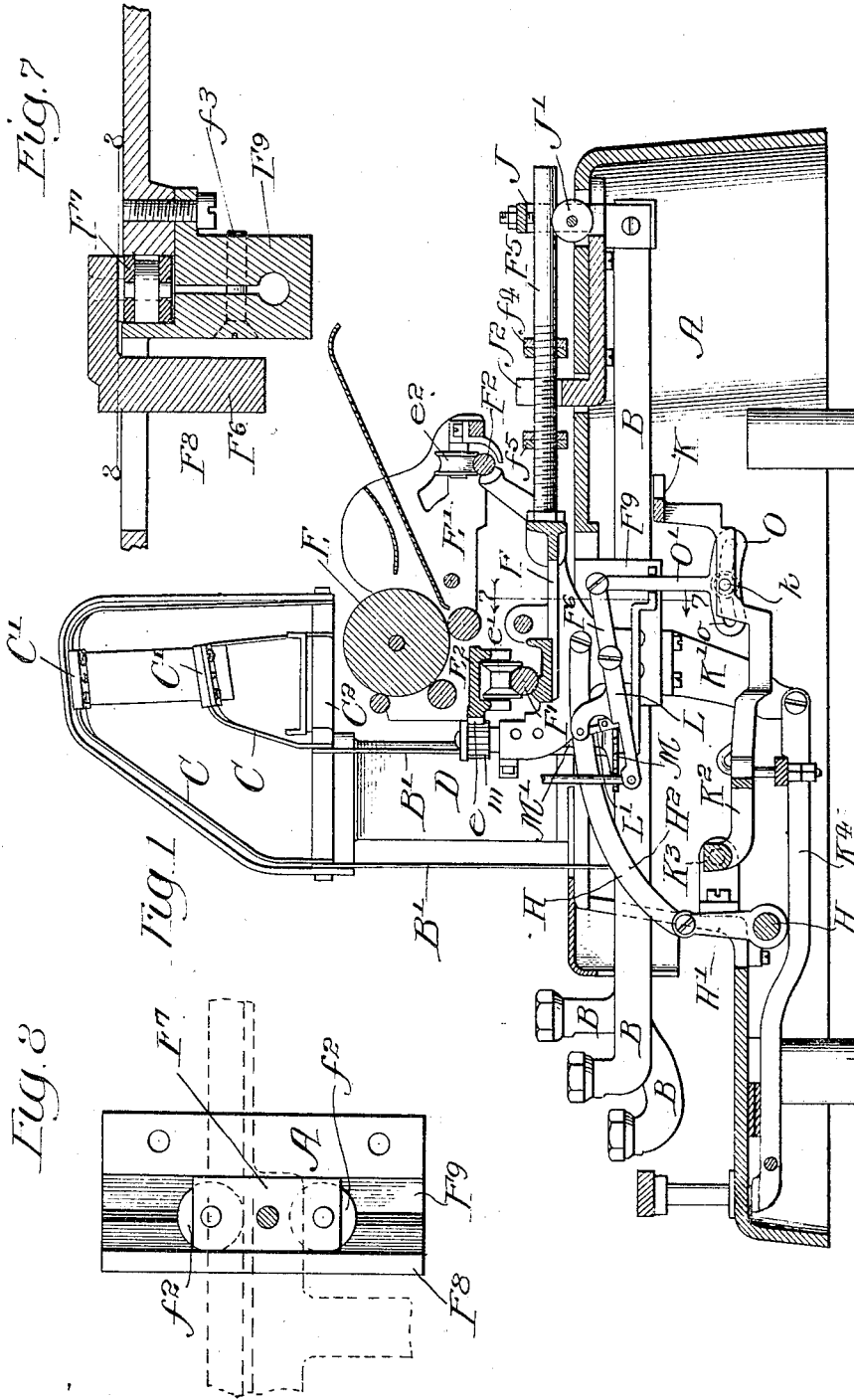

Witnesses:  
*H. P. Barnett*  
*C. P. Wilkins*

Inventor:  
*Harry Cross*  
 by *Poole & Brown His Attys*

No. 837,611.

PATENTED DEC. 4, 1906.

H. CROSS.  
TYPE WRITER.  
APPLICATION FILED NOV. 7, 1905.

4 SHEETS—SHEET 2.

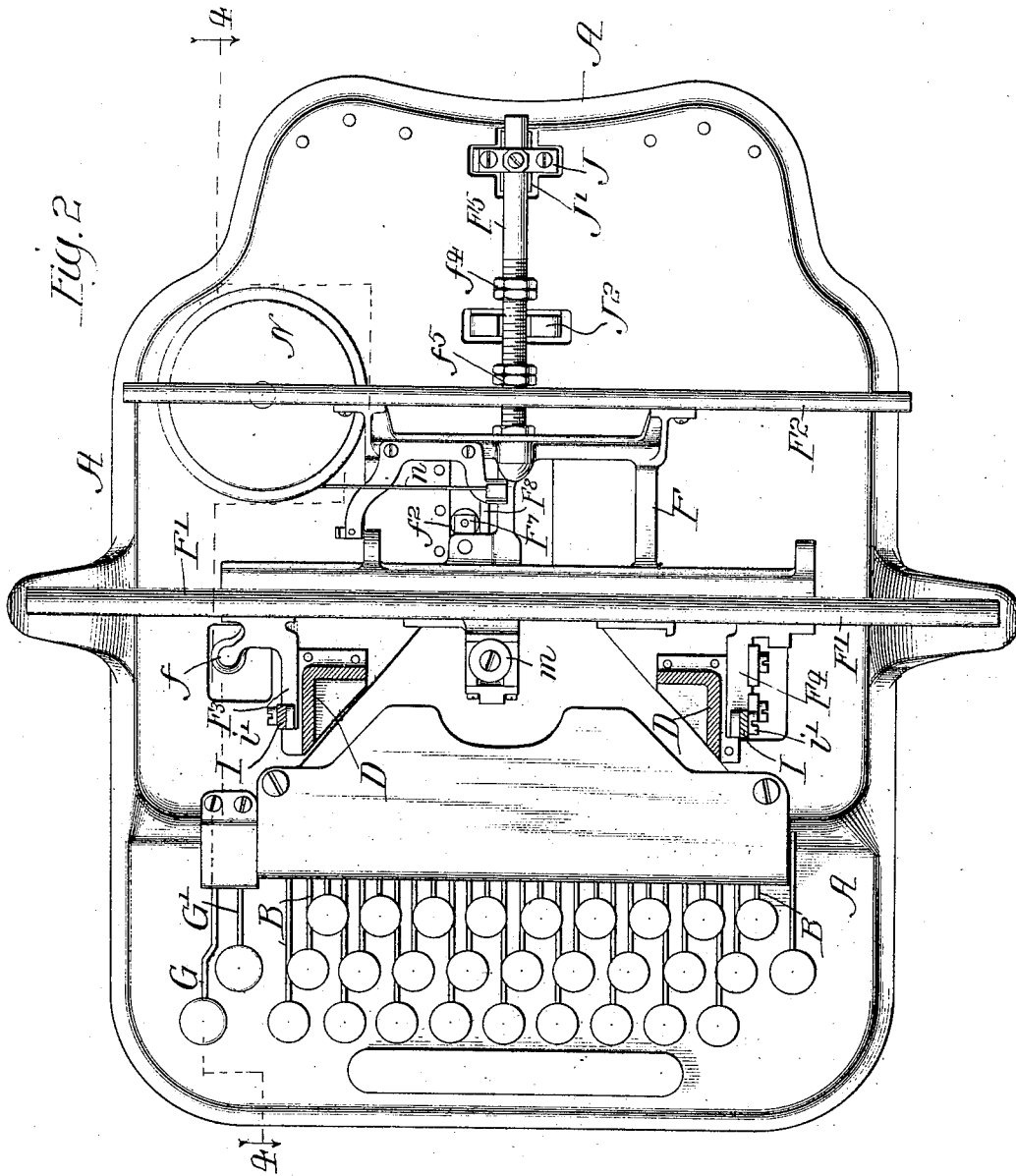

Witnesses:  
H. S. Bennett  
E. R. Wilkins

Inventor:  
Harry Cross  
by Poole & Moore  
his Attys

No. 837,611.

PATENTED DEC. 4, 1906.

H. CROSS.  
TYPE WRITER.

APPLICATION FILED NOV. 7, 1906.

4 SHEETS—SHEET 3.

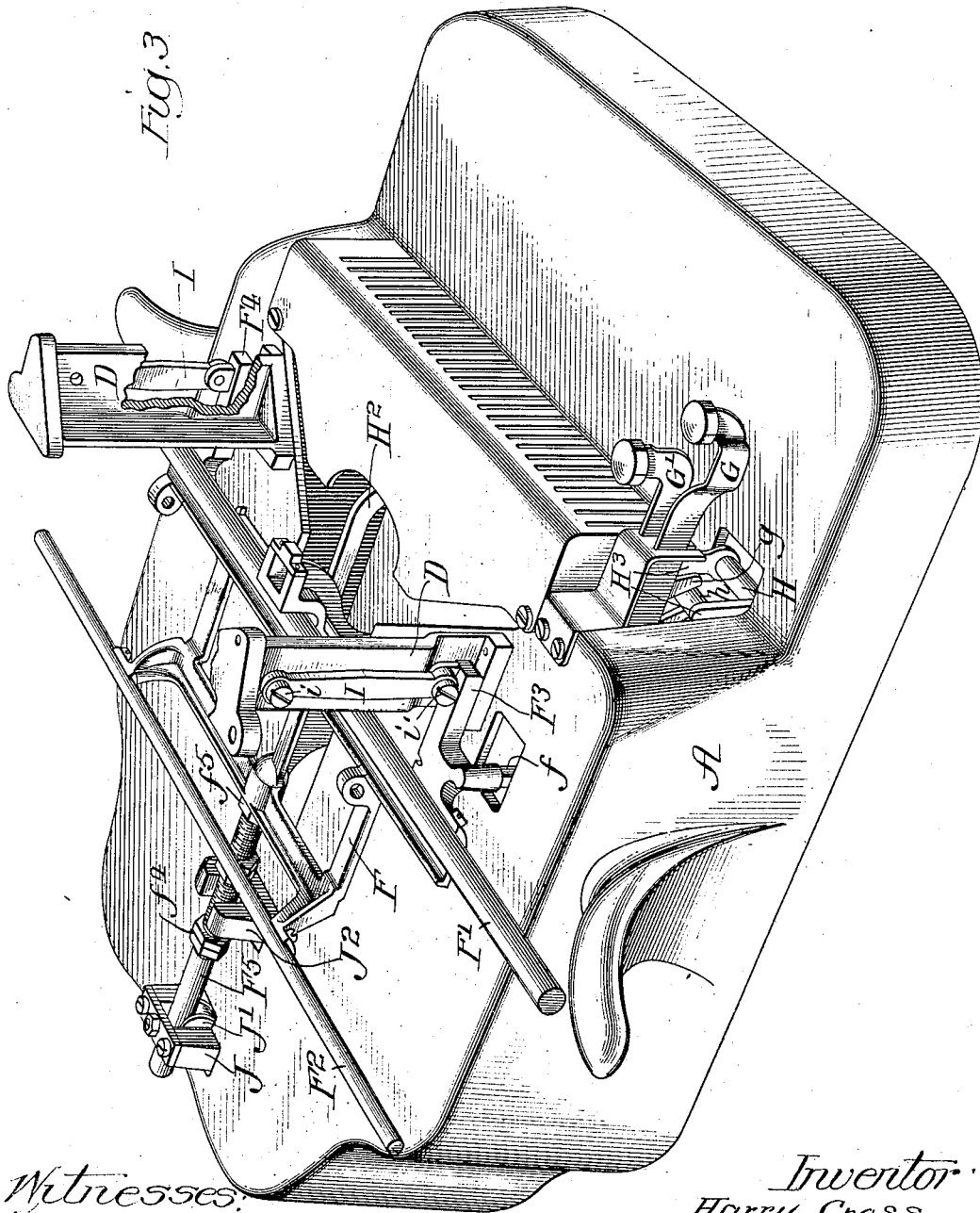

Witnesses:  
*S. H. Bennett*  
*A. R. Wilkins*

*Inventor*  
*Harry Cross*

by *Roole & Moore*  
*his Attys*

H. CROSS.  
TYPE WRITER.

APPLICATION FILED NOV. 7, 1905.

4 SHEETS—SHEET 4.

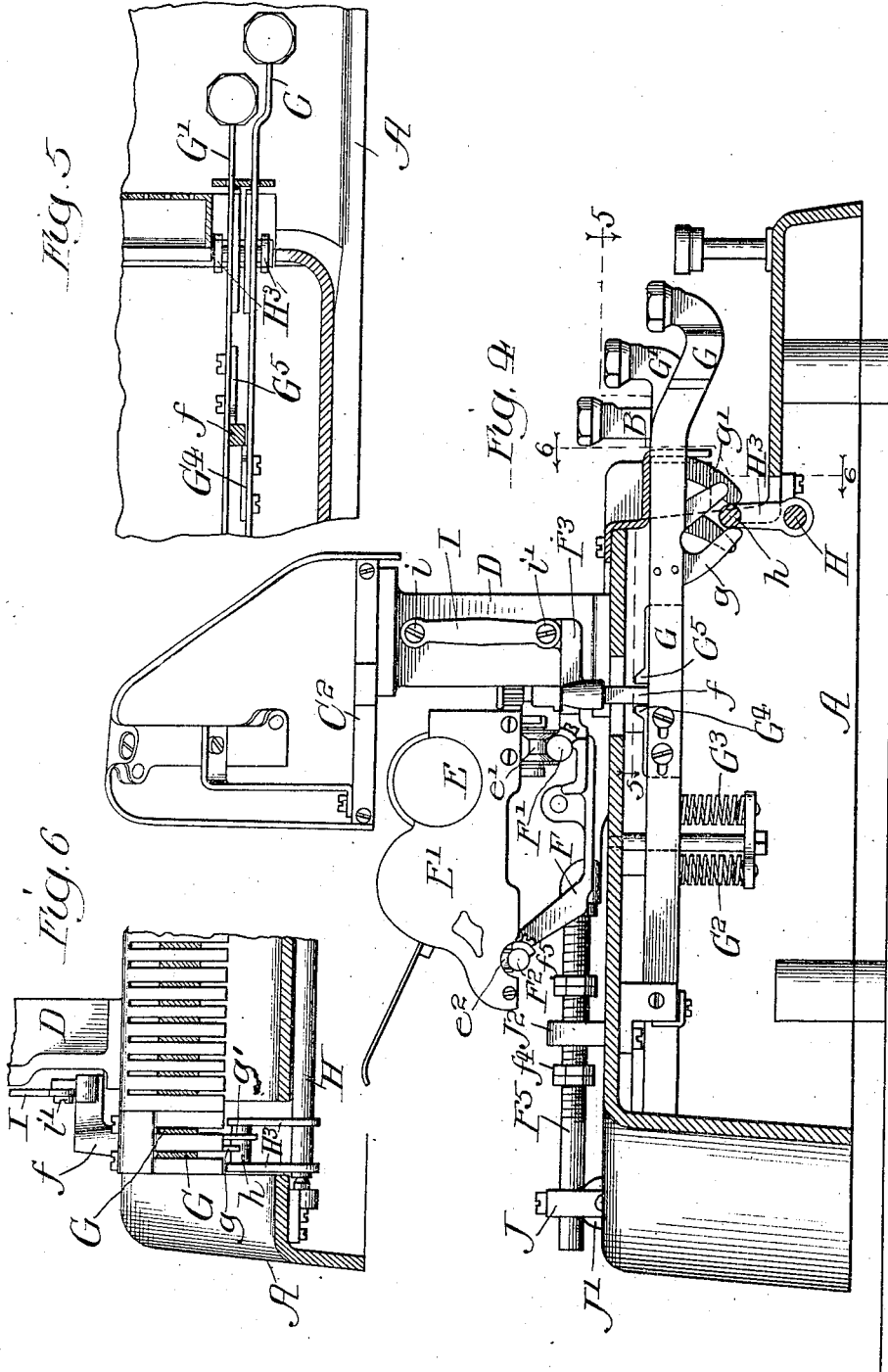

Witnesses:  
 H. G. Parrott  
 A. W. Wilkins

Inventor:  
 Harry Cross  
 by Poole & Brown  
 his Attys

# UNITED STATES PATENT OFFICE.

HARRY CROSS, OF WOODSTOCK, ILLINOIS, ASSIGNOR TO THE OLIVER TYPEWRITER COMPANY, OF CHICAGO, ILLINOIS, A CORPORATION OF ILLINOIS.

## TYPE-WRITER.

No. 837,611.

Specification of Letters Patent.

Patented Dec. 4, 1906.

Application filed November 7, 1905. Serial No. 286,269.

*To all whom it may concern:*

Be it known that I, HARRY CROSS, a citizen of the United States, and a resident of Woodstock, in the county of McHenry and State of Illinois, have invented certain new and useful Improvements in Type-Writers; and I do hereby declare that the following is a full, clear, and exact description thereof, reference being had to the accompanying drawings, and to the letters of reference marked thereon, which form a part of this specification.

This invention relates to improvements in type-writing machines of that kind having a platen-shift mechanism or device by which the paper-carriage is moved or shifted to bring the platen in position to receive an impression from either one of three types carried by each of the type-bars.

The improvements herein shown constituting the present invention are shown in the accompanying drawings as applied to an Oliver type-writing machine such as is shown in the prior patent to Thomas Oliver, No. 599,863, dated March 1, 1898. Said improvements, however, may also be applied to other kinds of type-writing machines of the double-shift type.

The invention consists in the matters hereinafter set forth, and more particularly pointed out in the appended claims.

My invention may be more readily understood by reference to the accompanying drawings, in which—

Figure 1 is a view in central vertical section of a type-writing machine equipped with the features constituting my invention. Fig. 2 is a plan section taken on a horizontal line above the base-plate of the machine with the carriage removed, showing the carriage-shift plate in plan view. Fig. 3 is a perspective view of the base-plate of the machine together with the shift-frame and parts concerned in supporting and moving said frame. Fig. 4 is a vertical section taken upon the section-line 4 4 of Fig. 2. Fig. 5 is a detail plan section taken upon line 5 5 of Fig. 4. Fig. 6 is a sectional elevation taken upon line 6 6 of Fig. 4. Fig. 7 is a detail cross-section taken upon line 7 7 of Fig. 1. Fig. 8 is a detail plan section of the parts shown in Fig. 7, taken on the line 8 8 of said Fig. 7.

First referring briefly to the general features of construction of the machine illus-

trated in the accompanying drawings, A indicates the base-plate of the machine, and B the key-levers, which extend from front to rear of the machine and which are pivoted at their rear ends to the rear part of said base-plate. Said levers are connected by links B' with type-bars C of the form employed in said Oliver type-writing machine and which are mounted in two groups located at opposite sides of the center line of the machine. Said type-bars C carry type-heads C', each provided with three types, as is common in such machines.

E indicates the platen, which is mounted in the paper-carriage, consisting of end plates E' and longitudinal frame-pieces, one of which, E<sup>2</sup>, is provided on its front edge with the rack-bar c of the carriage. The type-bars C are mounted in supporting-frames C<sup>2</sup>, which overhang the platen and carriage and are rigidly attached to supporting-standards D D, attached at their lower ends to the base-plate A and which are in front of the paper-carriage and platen.

F indicates as a whole a shifting frame on which the paper-carriage is mounted and which is capable of movement backwardly and forwardly from a central position, so that the platen may be brought under the striking-point of either of the three sets of types on the type-bars. Said shifting frame is provided with front and rear horizontal guide-bars F' F<sup>2</sup>, on which rest the rollers e' e<sup>2</sup> on the carriage-frame.

G G' indicate the shift-levers for actuating the shift-frame, which are located at the left-hand side of the machine.

H indicates a horizontal transverse rock-shaft by means of which motion is transmitted from said shift-levers to the shift-frame. The rock-shaft H is provided with an upwardly-extending crank-arm H', which is connected with the shift-frame by means of a connecting-bar H<sup>2</sup>. Said crank-shaft is provided beneath the shift-levers G G' with arms H<sup>3</sup> H<sup>3</sup>, carrying a crank-pin h, adapted to engage cam-slots formed in cam-plates g g', which are attached to and depend from the shift-levers.

G<sup>2</sup> G<sup>3</sup> are springs which act on the shift-levers to lift the same and which tend to return the shift-frame to its central position when shifted forwardly or rearwardly away from the same.

The shift-levers G G' are provided with forwardly and rearwardly facing stops G<sup>4</sup> G<sup>5</sup>, adapted to engage a rigid depending stop-arm f on the left-hand end of the shift-frame, so as to arrest the return movement of that end of the frame and hold it immovable in its central position. The shift-frame is guided or held from lateral movement when shifted by means of a guide-block F<sup>7</sup> thereon, which extends downwardly from the shift-frame and is engaged with a guide-groove on the base-plate, one vertical face of which is formed on the edge of the base-plate and the other face of which is formed on a flange F<sup>8</sup>, rising from a block F<sup>9</sup>, which is attached to and depends from the base-plate. The guide-block F<sup>7</sup> is provided with two anti-friction-rollers f<sup>2</sup> f<sup>2</sup>, which bear against the vertical guide-surface formed by the adjacent edge of the base-plate. To permit adjustment of the width of the guide-groove for the guide-block F<sup>7</sup>, the stationary block F<sup>9</sup> is provided with a slit extending downwardly through its upper part, and an adjusting-screw f<sup>3</sup> is inserted through the parts of said block at opposite sides of the slit and affords adjustment of the flange F<sup>8</sup> toward and from the opposite side of the guide-groove. The parts of the machine hereinbefore referred to correspond generally with the Oliver typewriting machine as heretofore constructed.

Referring now to the novel features of construction in the features constituting the means for supporting the shift-frame, which constitutes the subject-matter of the present invention, these parts are made as follows: Said shift-frame F is provided near its ends at opposite sides of the machine with forwardly-projecting arms F<sup>3</sup> F<sup>4</sup>, located adjacent to the frame-standards D D, by which the type-bar-supporting frames C<sup>2</sup> C<sup>2</sup> are sustained, and preferably at the outer faces of said standards. Said arms are connected with the said frame-standards D D at points above the arms by means of suspension-links or hangers I I, which are connected with the said standards and with the arms on the shift-frame by means of transversely-arranged horizontal pivots i i'. The links thus arranged serve to support the forward end of the shift-frame, while permitting forward and backward movement thereof from a central position by the swinging of the lower ends of said links I I forwardly and backwardly from the upright position thereof.

The rear end of the shift-frame F is shown in the drawings as supported and having sliding connection with the frame by the same means as shown in said prior Oliver patent—to wit, by means of a rearwardly-extending horizontal centrally-arranged guide rod or stem F<sup>5</sup>, which is rigidly attached to the rear part of the shift-frame and slides in a standard J on the base-plate of the machine, said standard being provided with a supporting-

roller J', on which said stem rests and moves in the shifting movement of the frame. Forward-and-rearward movement of the shift-frame is limited in this instance, as in the machine shown in said Oliver patent, by means of stop-nuts f<sup>4</sup> f<sup>5</sup> on the stem F<sup>5</sup>, arranged at opposite sides of and adapted for contact with a standard J<sup>2</sup>, said standard being mounted on the base-plate of the machine and is provided with a notch through which said stem F<sup>5</sup> freely passes.

By reason of the connection of the forward end of the shift-frame with the frame of the machine by suspension-links in the manner above described said frame, with the paper-carriage, has a slight rising-and-falling movement as the said parts are shifted from their central position through the action of one or the other of the shift-levers and in view of the fact that the carriage escapement mechanism (or devices for controlling the endwise movement of the carriage on the shift-frame under the action of the carriage-actuating spring) is carried by said shift-frame and operated from the space-bar of the machine. I have provided means for maintaining constant relation between said universal bar and the operative parts of the escapement mechanism, so that the operation of the escapement mechanism will be unaffected by such slight rising-and-falling movement of the shift-frame.

Now referring to the particular devices illustrated for controlling the movement of the carriage from the universal bar and in the escapement mechanism, which parts correspond generally with those of the Oliver typewriter as heretofore constructed, these parts are made as follows: K indicates the universal bar, on which all of the key-levers operate and which is connected by lateral arms K' K' and a central arm K<sup>2</sup>, which extend forwardly therefrom, with a rock-shaft K<sup>3</sup>, which is pivotally mounted on the forward part of the base-plate of the machine. K<sup>4</sup> K<sup>4</sup> indicate the space-key levers, which are connected with the central arm K<sup>2</sup> of the universal bar. The shift-frame F is provided with a depending part F<sup>6</sup>, on which is mounted an oscillating escapement-lever L, the forward end of which carries an escapement-pawl L', adapted for engagement with an escape-wheel M, mounted on an upright shaft M', the upper end of which is provided with a pinion m, that engages the carriage rack-bar e. The carriage is moved by the usual carriage-actuating spring, contained in a barrel N and which is connected with the carriage by the usual flexible connection n, Fig. 2. The escapement-lever L is operated from the universal bar K through the medium of a slotted yoke O, attached to the lower end of an upright bar O', which is pivoted at its upper end to the rear end of the escapement-lever L. Said slotted yoke O has a horizon-

tally-arranged slot *o*, which is engaged by means of a stud *k* on the universal-bar arm *K*<sup>2</sup>. Through the medium of said slotted yoke *O* vertical movement of the universal bar is transmitted to the escape-lever *L*, while backward-and-forward movement of said lever with the shift-frame is permitted by the said slot *o* without affecting the action of the escape devices, as is the case in the construction shown in said prior Oliver patent. As a novel construction of the parts illustrated the said slot *o* is made of curved form and lower at its ends than at its middle part, the curvature of the slot corresponding generally with the radius of the suspension-links or hangers *I* of the shift-frame. As a result of this construction the same relation is always maintained between the universal bar and the escapement-lever *L*, notwithstanding the slight vertical movement given to the shift-frame through the swinging of said suspension-links when the frame is shifted forwardly and rearwardly from its central position. In other words, the slight elevation of the shift-frame when it is moved forwardly or rearwardly from the central position is compensated for by the downward curvature of the ends of said slot *o* from the central part of said slot, which is engaged by the stud *k* at the time the shift-frame is in its central position.

The employment of suspension-links or hangers for sustaining the shift-frame from points on the machine-frame above the same when the parts are so arranged that the suspension-links or hangers in the intermediate or central position of the shift-frame stand at a vertical position and the movement of said shift-frame from such central position toward either limit of its throw has the effect of slightly lifting the carriage, as described, and has the important advantage, among others, of facilitating the prompt return of the shift-frame, carriage, platen, and other parts supported or carried by the shift-frame to the central or lower-case printing position, the weight of the parts which are moved in effecting the shift serving to aid in the return thereof to said central position. The extent of lifting movement is so slight that the weight of the parts affords no material resistance to the operation of the shift-keys, which latter moves with very slight resistance at the beginning of the movement, due to the fact that the shift-frame moves horizontally in the initial part of its movement, and it becomes possible to use springs of less strength to return the carriage, so that such springs may be made to give less resistance to the action of the shift-keys without decrease of their effectiveness in accomplishing the prompt return of the shift-frame than in the case of the construction where the platen has a horizontal movement, the prompt return of the shift-frame to its central position being

thus facilitated, while the shift-keys may be more easily operated, because requiring very slight pressure to start them on their downward movement and requiring a gradually-increased pressure of the finger as the shift-frame approaches the backward and forward limits of its movement. The supporting means for the shift-frame described has also the advantage of being very simple in its construction, of having few parts, and being exceedingly durable and not likely to get out of order.

It will of course be understood that the slight rising-and-falling movement of the platen will not have any effect whatsoever on the spacing of the letters in printing, the impact of the type on the paper taking place in such instance after the shifting movement of the platen is completed.

I claim as my invention—

1. In a type-writing machine, the combination with the machine-frame, of a paper-carriage, a shift-frame on which the paper-carriage has endwise movement for letter-spacing, and which is movable on the machine-frame to bring the paper into either one of a plurality of printing positions, and suspension-links or hangers pivoted at their lower ends to the shift-frame at their upper ends to the machine-frame and arranged to afford rising-and-falling movement of the shift-frame as the latter is moved away from and toward one of its printing positions.

2. In a type-writing machine, the combination with the machine-frame and type-bars bearing each three types, of a paper-carriage, a shift-frame on which the paper-carriage is supported and has endwise movement for letter-spacing, said shift-frame being movable in opposite directions from a central position to bring the paper into position to receive impressions from either of the three types on the type-bars, and suspension-links or hangers pivoted at their lower ends to the shift-frame and at their upper ends to the machine-frame and arranged to afford rising-and-falling movement to the shift-frame as the latter is moved in either direction away from and toward its said central position.

3. The combination with a type-writer frame, of a paper-carriage, a shift-frame on which the paper-carriage has endwise movement for letter-spacing and which is movable on the machine-frame to bring the paper into either one of three printing positions, a universal bar, means for controlling the letter-spacing movements of the paper-carriage, suspension-links or hangers connecting the shift-frame with the machine-frame and arranged to afford rising-and-falling movement of the shift-frame as the latter is moved in either direction away from and toward its central position, and operative connections between said universal bar and said means

for controlling the letter-spacing movements of the paper-carriage constructed to maintain constant the relation between said universal bar and the carriage-controlling means during the movements of the shift-frame.

4. The combination with type-bars, a paper-carriage, a base-plate, standards on the base-plate supporting the type-bars above the carriage, a shift-frame on which the paper-carriage has endwise movement for letter-spacing and which is movable on the machine-frame to bring the paper into either one of three printing positions, said shift-frame having arms which extend at the sides of said standards and supporting-links or hangers for the shift-frame pivoted to the arms on the shift-frame and to the standards at points above the said arms.

5. The combination with a paper-carriage, a shift-frame supporting the same, escapement mechanism for the carriage mounted on

the shift-frame and embracing an oscillating escapement-lever, means for supporting the shift-frame embracing suspension-links or hangers arranged to give rising-and-falling movement to the shift-frame when it is moved away from and toward its central position, and means for transmitting motion from the universal bar to said escapement-lever, embracing a slotted yoke and pin, the slot in the yoke being curved to compensate for the rising-and-falling movement given to the shift-frame by said links or hangers.

In testimony that I claim the foregoing as my invention I affix my signature, in presence of two witnesses, this 1st day of November, A. D. 1905.

HARRY CROSS,

Witnesses:

WM. H. O'BRIEN,  
F. A. DANIELS.